

R  
KAWASAKI STEEL GIHO  
Vol.31 (1999) No.4

T 7 J ; E D G " ° ~ + R K R T R

High-accuracy Gauge Control Technologies over the Full Length and Full Width of Cold Rolled Strip

O (Narihito Mizushima) Ž X (Toshihiro Fukaya) Ž (Hiroshi Kurakake)

:  
R Ž ° # # " ( \* T Ž Ž # 2 / G Ž Ž °  
( % \$ R Q M " ' † ! Ž ž ! † † ' + ~ R Ž  
\$ # M- + fl ' " D G N = F / A # R 5 7 J = A G C  
3 5 : E ° ( % 8 / > D 9 1 6 9 < . 9 B T R 3 5 : E - / fl ~ " °  
/ † \$ : L ? P , I L 1 H L G 3 @ < Ž ž 0 9 4 = H 9 B - R ' fl 0 9 4 =  
H 9 B T R 3 5 : E - / fl ~ i , ) # K # T R 3 5 : E - T  
7 J ; E Ž " † R R / fl i ž " ( \* T Ž Ž # R K R " fl \* 60.5 Q S  
# ! - / fl ~

Synopsis :

At tandem cold rolling mills in Kawasaki Steel, by means of applying newly developed strip longitudinal (rolling) and transverse gauge control systems, high accuracy of thickness of within 60.5 has been achieved over the full length and full width of cold rolled strip, as gauge accuracy in a coil in longitudinal and transverse directions has become an extremely important quality control item in the manufacturing of cold rolled sheets due to the stricter quality requirements of customers, in recent years. The longitudinal gauge accuracy has been improved by the development of a high-response drive system for a mill main motor, an all-stands gauge control system and a dynamic set-up control system. The transverse gauge accuracy has been improved by applying a one-side tapered work roll shifting method and the development of an edge drop control system in terms of the optimum use of an edge drop sensor.

(c)JFE Steel Corporation, 2003

High-accuracy Gauge Control Technologies  
over the Full Length and Full Width of Cold Rolled Strip

要旨

近年、お客様の品質要求の厳格化により、冷間タンデムミルの全長・全幅板厚制御技術の向上が求められている。本稿では、冷間タンデムミルにおける全長・全幅板厚制御技術の概要を説明し、その制御技術の向上について述べる。

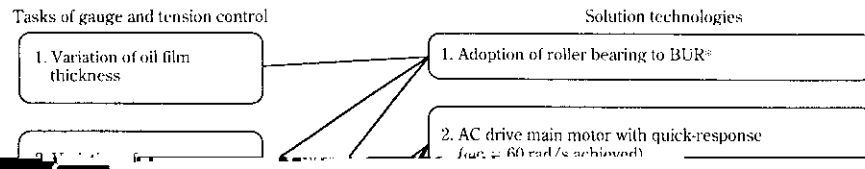

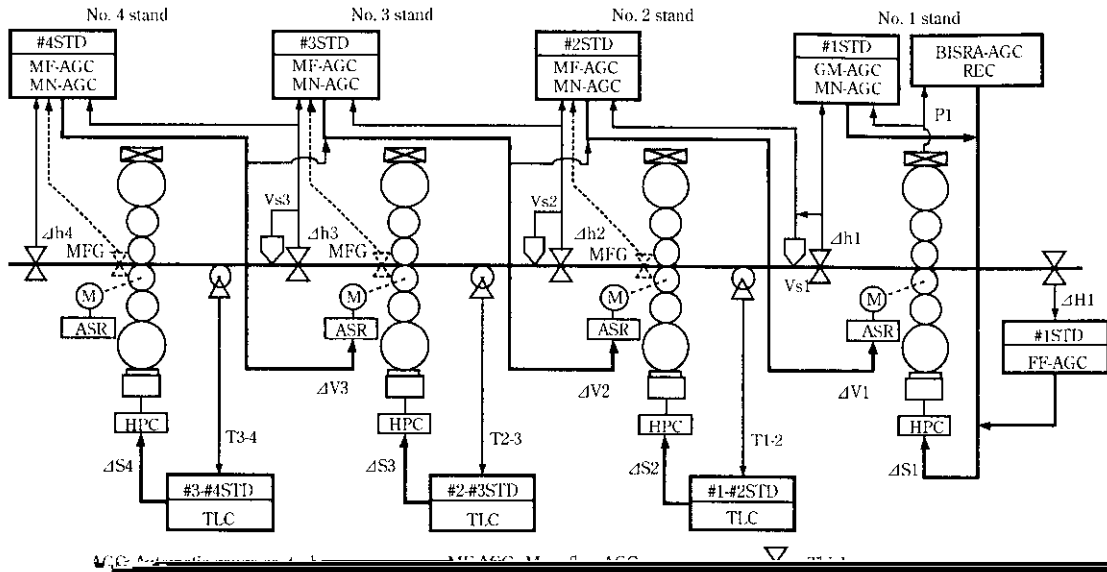

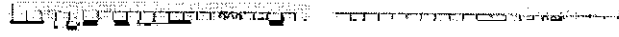

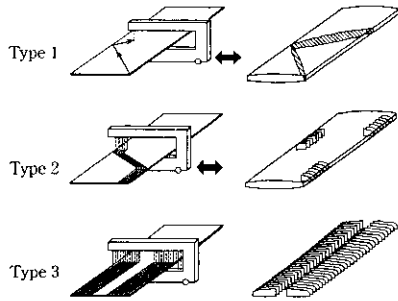

Fig. 10 Progress in measuring transverse thickness of strip

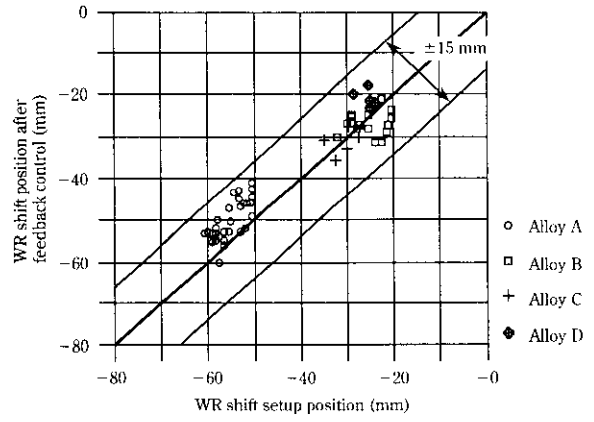

Fig. 12 Comparison of WR shift setup position and feedback

